

INSTALLATION INSTRUCTIONS

R-410A Duct Free Split System Air Conditioner and Heat Pump

Product Family: DFC4(A/H)3, DFF4(A/H)H



NOTE: Read the entire instruction manual before starting the installation.

TABLE OF CONTENTS

	PAGE
SAFETY CONSIDERATIONS	2
GENERAL	2
SYSTEM REQUIREMENTS	2-3
PARTS LIST	3
DIMENSIONS	4
SERVICE VALVE LOCATIONS	4
INSTALLATION TIPS	5
INDOOR UNIT INSTALLATION	5-7
Install Mounting Plate	5
Drill Hole in Wall for Connecting Piping, Drain & Wiring ..	5
Piping and Drainage Connections	6
Install Indoor Unit	6
Connect Field Wiring	6
Remote Control Installation	6
Control and Power Wiring from Outdoor Unit	7
OUTDOOR UNIT INSTALLATION	8-9
Installation Tips	8
Make Refrigerant Piping Connections	8
Wiring Connection	9
ELECTRICAL DATA	9
CONNECTION DIAGRAMS	10
SYSTEM VACUUM AND CHARGE	11-12
START-UP	12
TROUBLESHOOTING	13

SAFETY CONSIDERATIONS

Installing, starting up, and servicing air-conditioning equipment can be hazardous due to system pressures, electrical components, and equipment location (roofs, elevated structures, etc.).

Only trained, qualified installers and service mechanics should install, start-up, and service this equipment.

Untrained personnel can perform basic maintenance functions such as cleaning coils. All other operations should be performed by trained service personnel.

When working on the equipment, observe precautions in the literature and on tags, stickers, and labels attached to the equipment.

Follow all safety codes. Wear safety glasses and work gloves. Keep quenching cloth and fire extinguisher nearby when brazing. Use care in handling, rigging, and setting bulky equipment.

Read these instructions thoroughly and follow all warnings or cautions included in literature and attached to the unit. Consult local building codes and National Electrical Code (NEC) for special requirements. Recognize safety information. This is the safety-alert symbol . When you see this symbol on the unit and in instructions or manuals, be alert to the potential for personal injury. Understand these signal words: DANGER, WARNING, and CAUTION. These words are used with the safety-alert symbol. DANGER identifies the most serious hazards which **will** result in severe personal injury or death. WARNING signifies hazards which **could** result in personal injury or death. CAUTION is used to identify unsafe practices which **may**

result in minor personal injury or product and property damage. NOTE is used to highlight suggestions which **will** result in enhanced installation, reliability, or operation.



WARNING

ELECTRICAL SHOCK HAZARD

Failure to follow this warning could result in personal injury or death.

Before installing, modifying, or servicing system, main electrical disconnect switch must be in the OFF position. There may be more than 1 disconnect switch. Lock out and tag switch with a suitable warning label.



CAUTION

EQUIPMENT DAMAGE HAZARD

Failure to follow this caution may result in equipment damage or improper operation.

Do not bury more than 36 in. (914 mm) of refrigerant pipe in the ground. If any section of pipe is buried, there must be a 6 in. (152 mm) vertical rise to the valve connections on the outdoor units. If more than the recommended length is buried, refrigerant may migrate to the cooler buried section during extended periods of system shutdown. This causes refrigerant slugging and could possibly damage the compressor at start-up.

GENERAL

These instructions cover the installation, start-up and servicing of DFC4(A/H)3 outdoor and DFF4(A/H)H indoor units duct free systems.

SYSTEM REQUIREMENTS

IMPORTANT: Each refrigerant line must be insulated separately.

IMPORTANT: Use refrigeration grade tubing **ONLY**. No other type of tubing may be used. Use of other types of tubing will void manufacturer's warranty.

Piping

- Minimum refrigerant line length between the indoor and outdoor units is 10 ft. (3 m).
- The following maximum dimensions are allowed:

REFRIGERANT LINE LENGTHS ft. (m)			
Unit Size	Max Line Length	Max Elevation (ID over OD)	Max Elevation (OD over ID)
9K	65 (20)	35 (11)	35 (11)
12K	65 (20)	35 (11)	35 (11)
18K	100 (30)	50 (15)	50 (15)
24K	100 (30)	60 (18)	60 (18)

- The following are the piping sizes.

PIPE SIZES		
Unit Size	Mix Phase	Vapor
9K	1/4"	3/8"
12K	1/4"	1/2"
18K	1/4"	1/2"
24K	3/8"	5/8"

Refrigerant Charge

- The outdoor unit is factory charged.

REFRIGERANT CHARGE lb. (kg)		
Unit Size	Air Conditioner	Heat Pump
9K	2.3 (1.0)	2.4 (1.1)
12K	2.9 (1.3)	3.0 (1.4)
18K	4.4 (2.0)	TBD
24K	TBD	TBD

Power Wiring

- Consult local building codes, NEC (National Electrical Code) or CEC (Canadian Electrical Code) for special requirements.
- Connecting Cable:** Voltage drop on the connecting cable should be kept to a minimum. Use cable size and max length below:

#18 AWG	50 Feet (16 m)
#16 AWG	100 Feet (33 m)

- Allow sufficient space for airflow and servicing unit. See Fig. 1 and 2 for minimum required distances between unit and walls or ceilings.
- Do not install indoor units near a direct source of heat such as direct sunlight or a heating appliance.

Model Size	Power Source	MIN CKT AMP MAX FUSE/CB AMP	AWG (min.)
			Connecting Cable** (outdoor to indoor)
9k	115-1-60	12/20	18
12k		15/25	
12k	208/230-1-60	9/15	18
18k		11/20	18
24k		14/25	

** Four conductor cable to comply with NEC and local codes.

PARTS LIST

Part No.	Name of Part	Qty
1	Mounting Plate	1
2	Mounting Screw ST3.9x25-C-H	8
3	Anchor	8
4	Remote Control	1
5	Remote Control Holder	1
6	Mounting Screw B ST2.0x10-C-H	2

Part No.	Name of Part	Qty
1	Mounting Plate	1
2	Mounting Screw A ST3.9x25-C-H	8
3	Anchor	8
4	Remote Control	1
5	Remote Control Holder	1
6	Mounting Screw B ST2.0x10-C-H	2

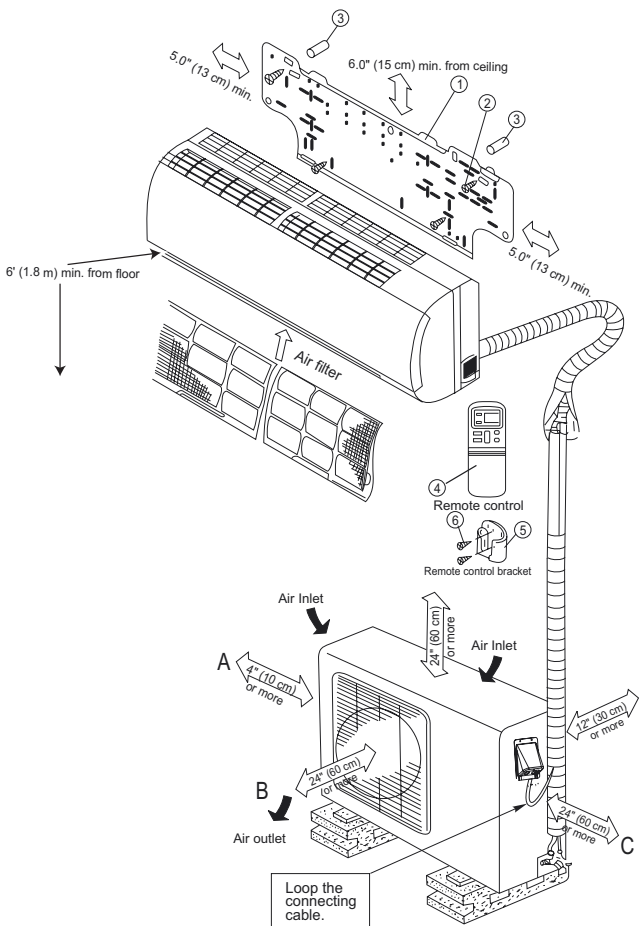

A07334

**Fig. 1 – DFC4(A/H)3, DFF4(A/H)H 09-12
Parts List and Clearances**

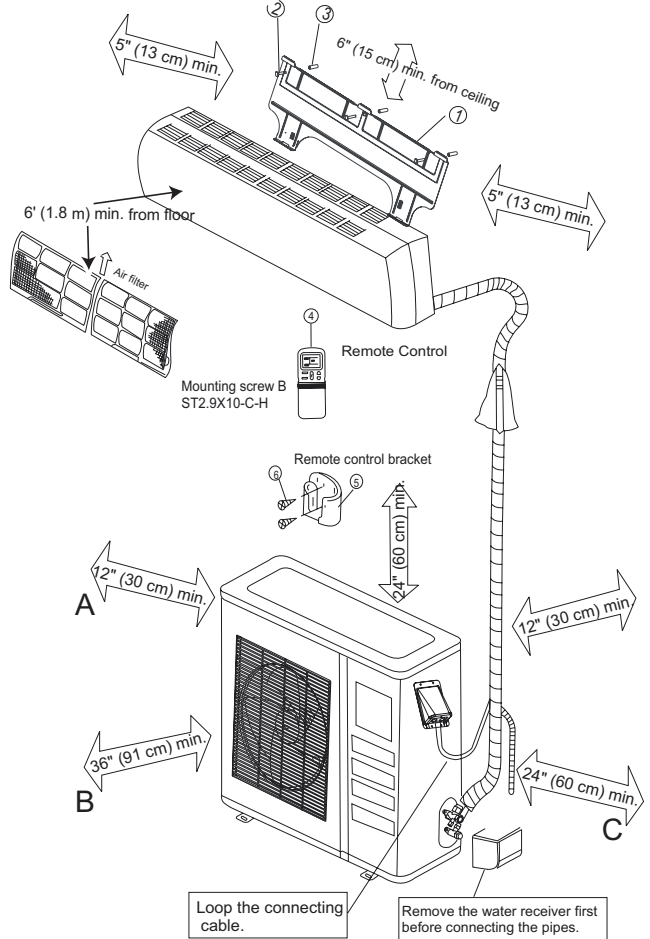

A07335

**Fig. 2 – DFC4(A/H)3, DFF4(A/H)H
Parts List and Clearances**

Note:

- If the outdoor unit is higher than the indoor unit, prevent rain from flowing into the indoor unit along the connection pipe by making a downward arc in the connection pipe before it enters the wall to the indoor unit. This will ensure that rain will drip from the connection pipe before it enters the wall.
- The illustration above is only a sketch. Different models may be slightly different.

DIMENSIONS

INDOOR

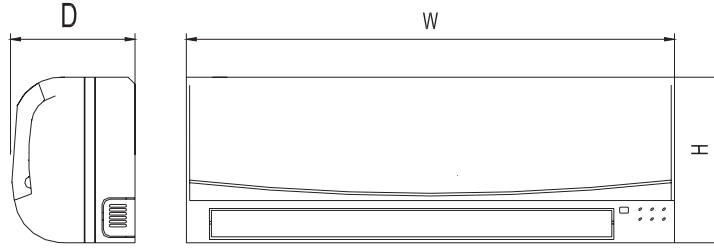

Model Size	W in. (mm)	H in. (mm)	D in. (mm)	Weight lb (kg)
9K	32.09 (815)	11.02 (280)	7.68 (195)	24.2 (11)
12K	35.67 (906)	11.26 (286)	9.25 (235)	33.0 (15)
18K	49.21 (1250)	12.80 (325)	9.06 (230)	55.0 (25)
24K	49.21 (1250)	12.80 (325)	9.06 (230)	55.0 (25)

OUTDOOR

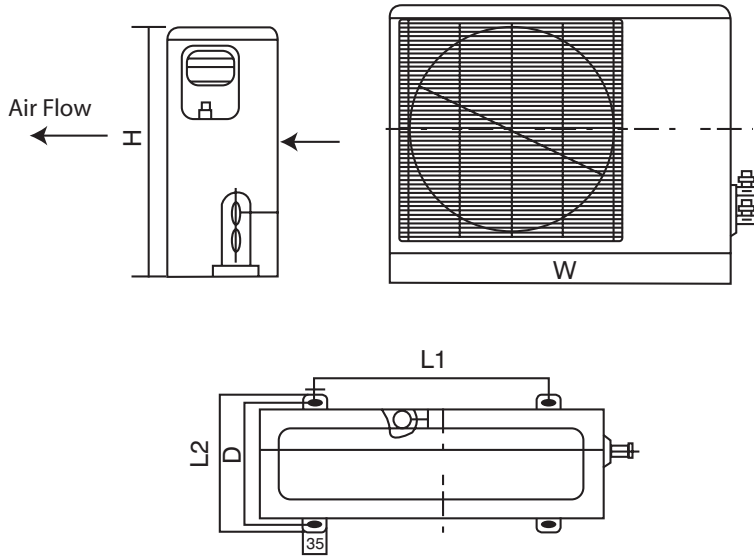

Model Size	W in. (mm)	H in. (mm)	D in. (mm)	L1 in. (mm)	L2 in. (mm)	Weight lb (kg) Cooling Only	Weight lb (kg) Heat Pumps
9K	30.71 (780)	21.26 (540)	10.87 (276)	21.61 (549)	11.81 (300)	77.0 (35)	79.2 (36)
12K	29.92 (760)	23.23 (590)	11.42 (290)	20.87 (530)	12.40 (315)	85.8 (39)	90.2 (41)
18K	33.07 (840)	27.36 (695)	13.19 (335)	22.05 (560)	14.17 (360)	125.4 (57)	125.4 (57)
24K	31.16 (893)	33.86 (860)	13.11 (333)	23.11 (588)	13.98 (355)	159.5 (72)	160.6 (73)

SERVICE VALVE LOCATIONS

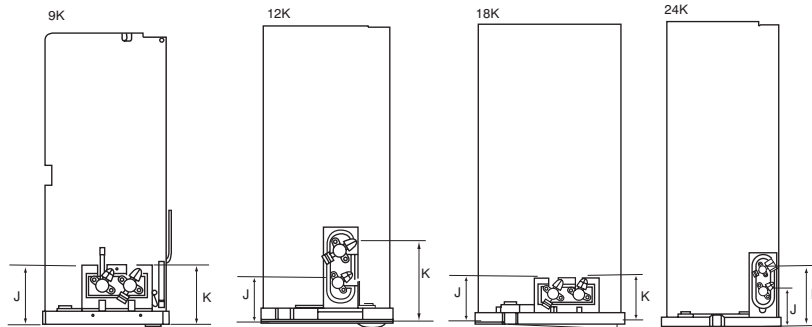

Service Valve Locations	9K in. (mm)	12K in. (mm)	18K in. (mm)	24K in. (mm)
J	3.46 (88)	3.19 (81)	3.46 (88)	4.02 (102)
K	3.46 (88)	5.63 (143)	3.62 (92)	6.57 (167)

INSTALLATION TIPS

Ideal installation locations include:

Indoor Unit

- A location where there are no obstacles near inlet and outlet area.
- A location which can bear the weight of indoor unit.
- A location which provides appropriate clearances as outlined in Fig. 1 and Fig. 2 (pg. 3).

Outdoor Unit

- A location which is convenient to installation and not exposed to strong wind. If unit is exposed to strong winds it is recommended that a wind baffle be used. Contact your representative for drawings.
- A location which can bear the weight of outdoor unit and where the outdoor unit can be mounted in a level position.
- A location which provides appropriate clearances as outlined in Fig. 1 and Fig. 2 (pg. 3).
- Do not install the indoor or outdoor units in a location with special environmental conditions. For those applications, contact your representative.

INDOOR UNIT INSTALLATION

INSTALL MOUNTING PLATE

The mounting plate will look like one of the following depending on model size:

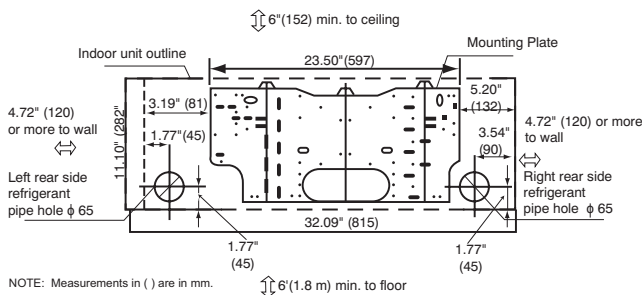

Fig. 3 – Mounting Plate- Model size 09

A07338

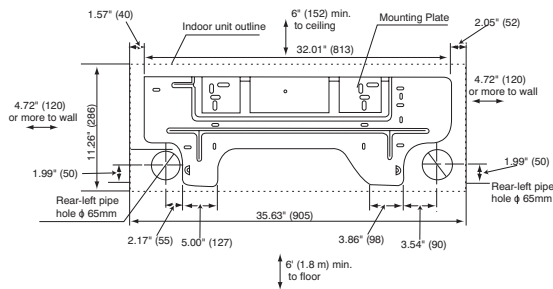

Fig. 4 – Mounting Plate- Model size 12

A07339

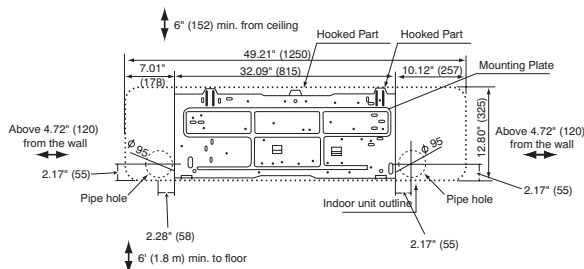

Fig. 5 – Mounting Plate- Model sizes 18 – 24

A07340

1. Carefully remove the mounting plate, which is attached to the back of the indoor unit.
2. The mounting plate should be located horizontally and level on the wall. All minimum spacings shown in Fig. 3, 4, and 5 should be maintained.
3. If the wall is block, brick, concrete or similar material, drill .2" (5 mm) diameter holes and insert anchors for the appropriate mounting screws.
4. Attach the mounting plate to the wall.

DRILL HOLE IN WALL FOR INTERCONNECTING PIPING, DRAIN AND WIRING

Refrigerant Line Routing

The refrigerant lines may be routed in any of the four directions shown in Fig. 7.

If piping is going through the back:

1. Determine pipe hole position using the mounting plate as a template. Drill pipe hole diameter per chart below. The outside pipe hole is 1/2-in. (13 mm) min. lower than inside pipe hole, so it slants slightly downward.

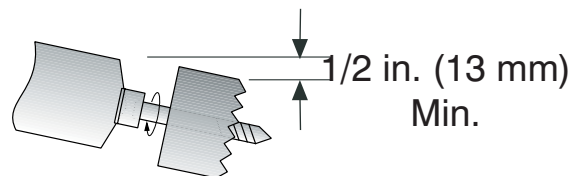

INDOOR OUTDOOR

Fig. 6 – Drill Holes

Model Size	Hole Diameter in. (mm)
09, 12	2.75 (70)
18, 24	3.75 (95)

If piping is going through the right or left side:

1. Use a small saw blade to carefully remove the corresponding plastic covering on side panel and drill the appropriate size hole where the pipe is going through the wall.

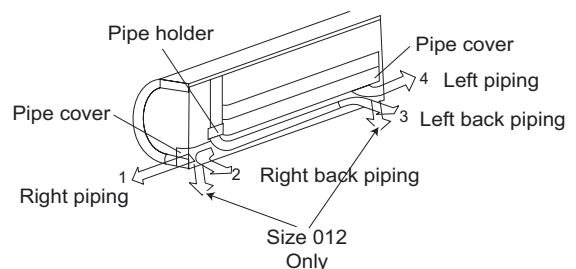

Fig. 7 – Piping Locations

PIPING AND DRAINAGE CONNECTIONS

NOTE: Before making any connections, remove the front cover on unit size 12 only. This is not required on unit sizes 09, 18, and 24.

Make Connections

1. Orient the refrigerant lines on the fan coils to match the connection points.
2. Put upper claw at back of indoor unit on upper hook of Mounting Plate, move indoor unit from side to side to see that it is securely hooked. See Fig. 11.
3. Run electrical cable, refrigerant lines and drain line through hole in the wall. All lines must be protected where they pass through the wall.
4. Piping can be connected by lifting indoor unit with a cushioning material between indoor unit and wall. See Fig. 10.
5. Connect the refrigerant lines using a flare connection. See *System Requirements* section for proper size. Both lines must be separately insulated.
6. Connect the drain line. The drain line must not have a trap anywhere in its length, must pitch downwards, and must be insulated up to the outside wall. See Fig. 8.

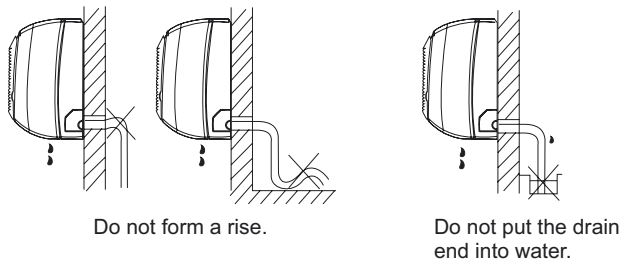

Fig. 8 – Proper Drain Hose Installation

A07342

NOTE: For proper orientation of the refrigerant piping, electrical cable, and drain lines, refer to Fig. 9

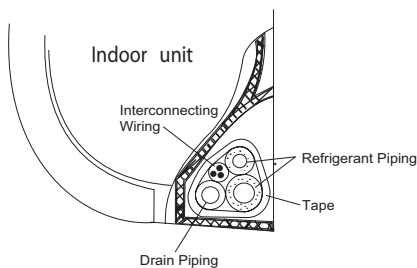

Fig. 9 – Proper Orientation

A07346

NOTE: For applications where gravity cannot be used for drainage, a condensate pump accessory is available. Consult the condensate pump Installation Instructions for more information.

INSTALL INDOOR UNIT

1. Be sure to remove cushioning after making all corrections.
2. Push lower part of indoor unit up on wall, then move indoor unit from side to side, up and down to check if it is hooked securely.

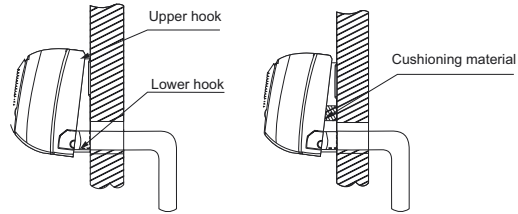

A07347

Fig. 10 – Indoor Unit Installation

CONNECT FIELD WIRING

NOTE: A disconnect should be provided per NEC and local codes.

For Sizes 09, 18, 24

1. Lift the panel, loosen the screws, and remove the control box cover.
2. Connect wires to the terminal block per the connection diagrams (Fig. 16, p.10) corresponding to the correct unit capacity and voltage.
3. Cover the control box and close the front panel.

For Size 12

The front cover should have been removed.

1. Loosen the screws and remove the control box cover.
2. Connect wires to the terminal block per the connection diagrams (Fig. 16, p.10) corresponding to the correct unit capacity and voltage.
3. Cover the control box and install the front cover.

REMOTE CONTROL INSTALLATION

Mounting Bracket (if installed on the wall)

1. Use the two screws supplied with control to attach Mounting Bracket to wall in location selected by customer and within operating range.
2. Install batteries in Remote Control.
3. Place Remote Control into remote control Mounting Bracket.
4. For remote control operation, refer to the unit Owner's Manual.

CONTROL AND POWER WIRING FROM OUTDOOR UNIT

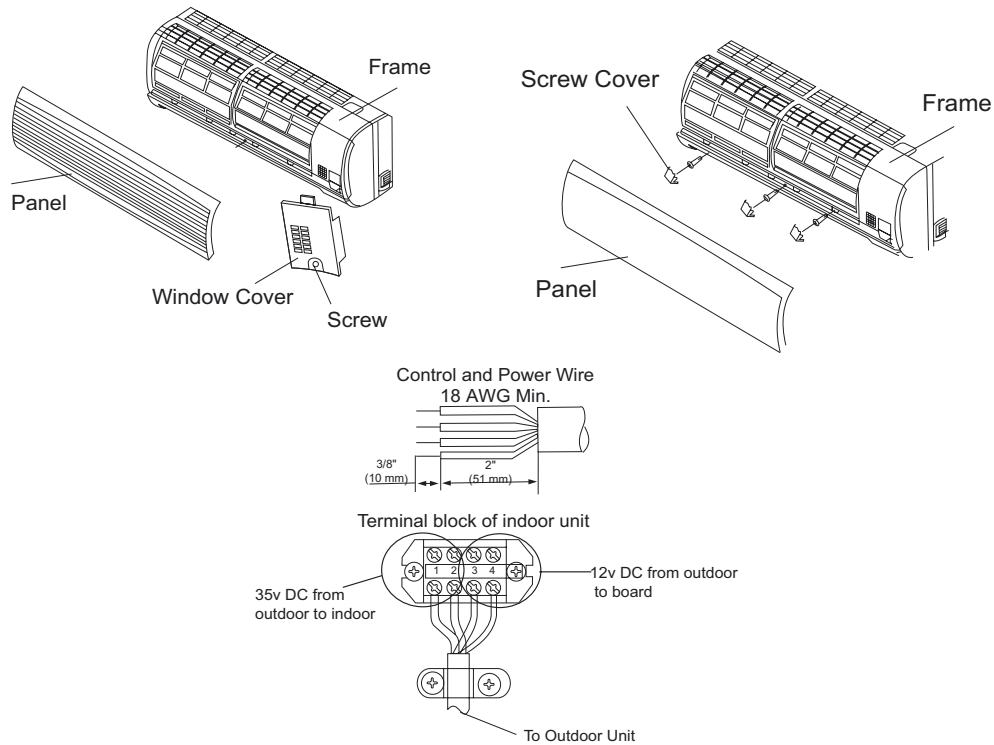

Fig. 11 – Control and Power Wiring – model size 9k – 12k

A07348

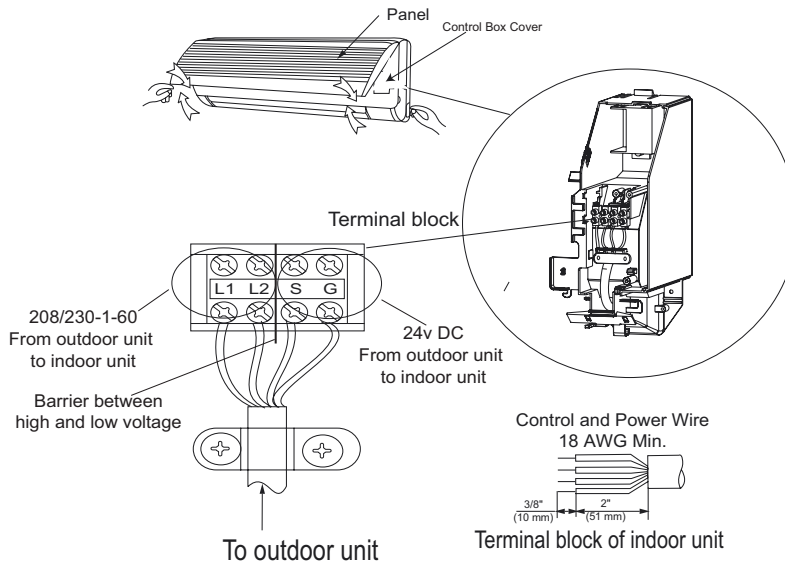

Fig. 12 – Control and Power Wiring – model size 18k-24k

A07349

OUTDOOR UNIT INSTALLATION

INSTALLATION TIPS

- Install the outdoor unit on a rigid base to support unit in a level position.
- Make sure that the discharge air is not blocked.
- For applications requiring cooling with outdoor temperatures below 55°F (13°C), a low ambient control is available. Consult the Installation Instruction for the low ambient kit for further information.
- If the installation location may be exposed to strong wind, use a wind baffle. See Fig. 13. Check with your representative to obtain drawings for wind baffles.

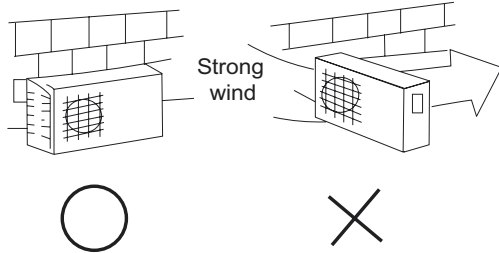

Fig. 13 – High Wind Installation

A07350

MAKE REFRIGERANT PIPING CONNECTIONS (OUTDOOR UNIT)

IMPORTANT: Use refrigeration grade tubing ONLY. No other type of tubing may be used. Use of other types of tubing will void manufacturer's warranty.

Do not open service valves or remove protective caps from tubing ends until all the connections are made.

Bend tubing with bending tools to avoid kinks and flat spots. Keep the tubing free of dirt, sand, moisture, and other contaminants to avoid damaging the refrigerant system.

Avoid sags in the suction line to prevent the formation of oil traps. Insulate each tube with minimum 3/8-in. (10 mm) wall thermal pipe insulation. Inserting the tubing into the insulation before making the connections will save time and improve installation quality.

1. Remove service valve cover if provided with unit.
2. Cut tubing with tubing cutter. Remove service connection if provided with unit.
3. Install correct size flare nut onto tubing and make flare connection.
4. Apply a small amount of refrigerant oil to the flare connection on the tubing.
5. Properly align tubing in with service valve.
6. Tighten flare nut and finish installation using two wrenches as shown in Fig. 14.

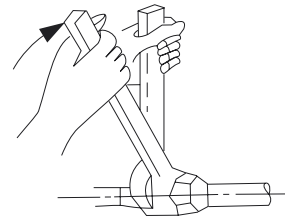

Fig. 14 – Tighten Flare Nut

A07354



CAUTION

EQUIPMENT DAMAGE HAZARD

Failure to follow this caution may result in equipment damage or improper operation.

Excessive torque can break flare nut depending on installation conditions.

WIRING CONNECTION

1. Remove field wiring cover from unit by loosening screws.
2. Remove caps on conduit panel.
3. Connect conduit to conduit panel.
4. Properly connect both power supply and control lines to terminal block per the connection diagram for the appropriate unit capacity and voltage. (See Fig. 16, p. 10)
5. Ground unit in accordance with NEC and local electrical codes.
6. Use lock nuts to secure conduit.
7. Attach field wiring cover.

⚠ CAUTION

EQUIPMENT DAMAGE HAZARD

Failure to follow this caution may result in equipment damage or improper operation.

- Be sure to comply with local codes while running wire from indoor unit to outdoor unit.
- Every wire must be connected firmly. Loose wiring may cause terminal to overheat or result in unit malfunction. A fire hazard may also exist. Therefore, be sure all wiring is tightly connected.
- No wire should be allowed to touch refrigerant tubing, compressor or any moving parts.
- Disconnecting means must be provided and shall be located within sight and readily accessible from the air conditioner.
- Connecting cable with conduit shall be routed through hole in the conduit panel.

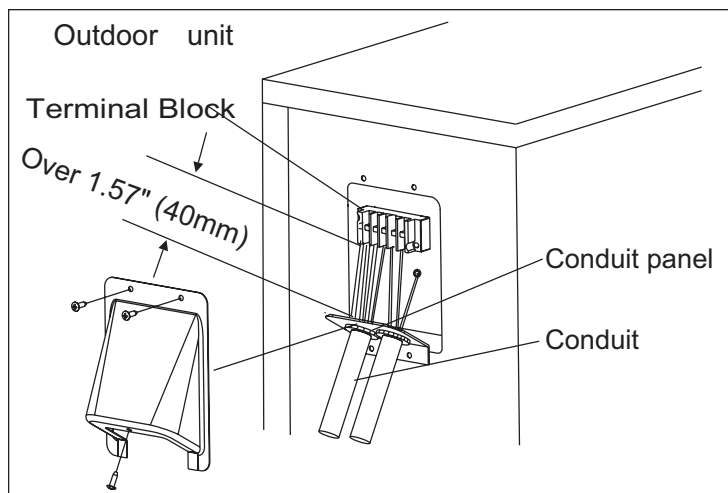

Fig. 15 – Field Wiring

A07455

ELECTRICAL DATA

UNIT SIZE	OPERATING VOLTAGE	COMPRESSOR			OUTDOOR FAN			INDOOR FAN				MCA	MAX FUSE/CB AMP
	MAX/MIN	VOLTS-PH-HZ	RLA	LRA	FLA	HP	W	VOLTS	FLA	HP	W		
09	127/104	115-1-60	7.5	40	0.69	0.102	23	35 DC	1.1	0.034	20	12	20
12			9.9	47					1.18	0.044	25		
18	253/187	208/230-1-60	7.3	32.6	0.78	0.224	53	208/230-1-60	0.26	0.075	31	11	20
24			9.7	34.8					0.62	0.218	100		

CONNECTION DIAGRAMS

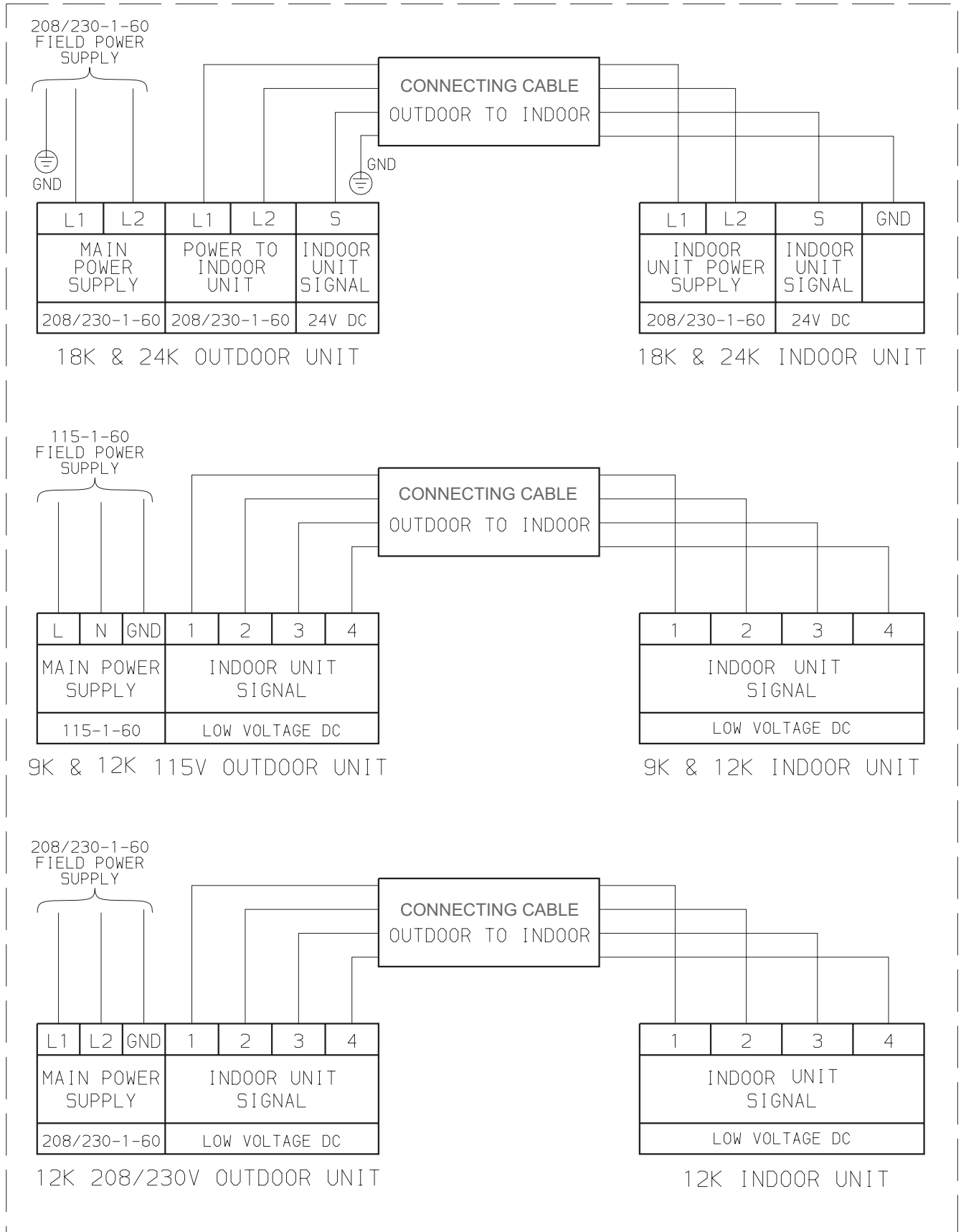

Fig. 16 – Connection Diagrams

A07654

CAUTION

UNIT DAMAGE HAZARD

Failure to follow this caution may result in equipment damage or improper operation.

Never use the system compressor as a vacuum pump.

Refrigerant tubes and indoor coil should be evacuated using the recommended deep vacuum method of 500 microns. The alternate triple evacuation method may be used if the procedure outlined below is followed. Always break a vacuum with dry nitrogen.

SYSTEM VACUUM AND CHARGE

Using Vacuum Pump

1. Completely tighten flare nuts A, B, C, D, connect manifold gage charge hose to a charge port of the low side service valve.
2. Connect charge hose to vacuum pump.
3. Fully open the low side of manifold gage.
4. Start vacuum pump
5. Evacuate using either deep vacuum or triple evacuation method.
6. After evacuation is complete, fully close the low side of manifold gage and stop operation of vacuum pump.
7. The factory charge contained in the outdoor unit is good for up to 25 ft. (8 m) of line length.
8. Disconnect charge hose from charge connection of the low side service valve.
9. Fully open service valves B and A.
10. Securely tighten caps of service valves.

Deep Vacuum Method

The deep vacuum method requires a vacuum pump capable of pulling a vacuum of 500 microns and a vacuum gage capable of accurately measuring this vacuum depth. The deep vacuum method is the most positive way of assuring a system is free of air and liquid water. (See Fig. 19)

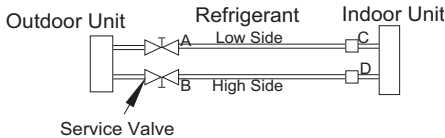

Fig. 17 – Service Valve

A07360

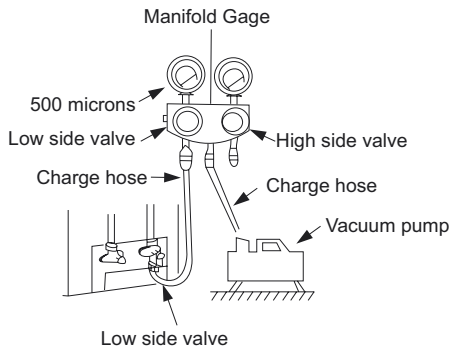

Fig. 18 – Manifold

A07361

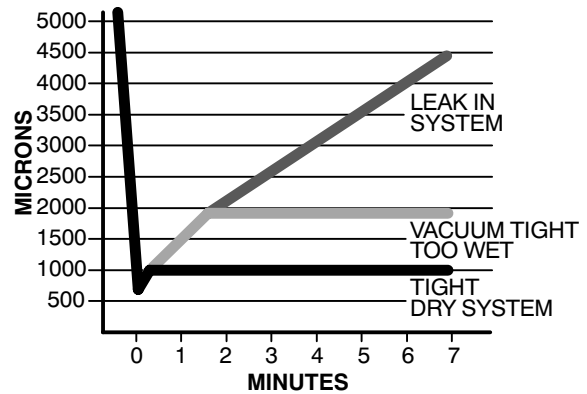

Fig. 19 – Deep Vacuum Graph

A95424

Triple Evacuation Method

The triple evacuation method should only be used when vacuum pump is only capable of pumping down to 28 in. of mercury vacuum and system does not contain any liquid water. Refer to Fig. 20 and proceed as follows:

1. Pump system down to 28 in. of mercury and allow pump to continue operating for an additional 15 minutes.
2. Close service valves and shut off vacuum pump.
3. Connect a nitrogen cylinder and regulator to system and open until system pressure is 2 psig.
4. Close service valve and allow system to stand for 1 hr. During this time, dry nitrogen will be able to diffuse throughout the system absorbing moisture.
5. Repeat this procedure as indicated in Fig. 20. System will then be free of any contaminants and water vapor.

(see next page)

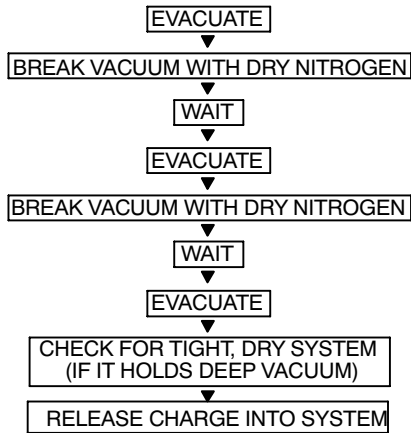

Fig. 20 – Triple Evacuation Method

Final Tubing Check

IMPORTANT: Check to be certain factory tubing on both indoor and outdoor unit has not shifted during shipment. Ensure tubes are not rubbing against each other or any sheet metal. Pay close attention to feeder tubes, making sure wire ties on feeder tubes are secure and tight.

START-UP

Test Operation

Perform test operation after completing gas leak and electrical safety check.

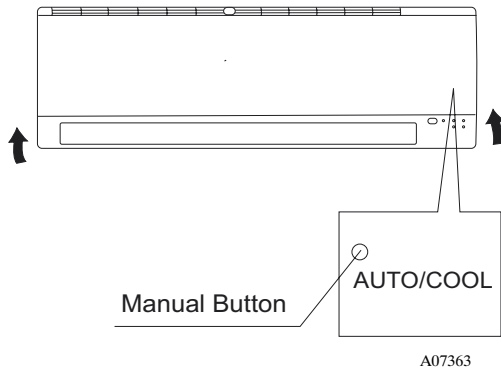

1. Push the "ON/OFF" button on Remote Control to begin testing.

NOTE: A protection feature prevents air conditioner from being activated for approximately 3 minutes.

2. Push MODE button, select COOLING, HEATING, FAN mode to check if all functions work correctly.
3. When ambient temperature is lower than 63°F/17°C, the unit cannot be controlled by Remote Control to run in cooling mode. For this condition, manual operation must be used.
 - (1.) Open front panel of the indoor unit;
 - (2.) Push the manual switch once to energize the unit.
4. Be sure to set manual switch to "OFF" (by pushing it twice) after finishing test operation.

NOTE: For Heat Pumps, follow the same procedure.

SYSTEM CHECKS

1. Conceal the tubing where possible.
2. Make sure that the drain tube slopes downward along its entire length.
3. Ensure all tubing and connections are properly insulated.
4. Fasten tubes to the outside wall, when possible.
5. Seal the hole through which the cables and tubing pass.

INDOOR UNIT

1. Do all Remote Control buttons function properly?
2. Do the display panel lights work properly?
3. Does the air deflection louver function properly?
4. Does the drain work?

OUTDOOR UNIT

1. Are there unusual noises or vibrations during operation?

Explain Following Items To Customer With The Aid Of The Owner's Manual:

1. How to turn air conditioner on and off; selecting COOLING, HEATING and other operating modes; setting a desired temperature; setting the timer to automatically start and stop air conditioner operation; and all other features of the Remote Control and display panel.
2. How to remove and clean the air filter.
3. How to set air deflection louver.
4. Explain care and maintenance.
5. Present the Owner's Manual and installation instructions to customer.

TROUBLESHOOTING

GENERAL SYSTEM GUIDE

Cooling

Operation Lamp	Timer Lamp	Failure Mode
☆	X	Indoor fan speed has been out of control for over 1 minute
☆	On	Indoor room temp. or evaporator sensor is open circuit or short circuited
X	☆	Compressor over-current protection has been activated four times
On	☆	EEROM error
☆	☆	Indoor unit communication error (Illuminates simultaneously)

Heat

Operation Lamp	Timer Lamp	Defrosting Lamp	Auto Lamp	Failure Mode
☆	☆	☆	☆	Over-current protection of the compressor occurs four times
X	☆	X	X	Indoor room temp. sensor is open circuit or short circuited
☆	X	X	X	Temp. sensor on indoor evaporator is open circuit or short circuited
X	X	☆	X	Temp. sensor on outdoor condenser is open circuit or short circuited (not cooling only modes)
X	X	☆	☆	Outdoor unit protects (outdoor temp. sensor, phase order, etc.)
X	☆	X	☆	EEROM error
X	X	X	☆	Indoor unit communication error

☆ = Flashing
 X = Off

For additional diagnostic information, refer to the Service Manual.

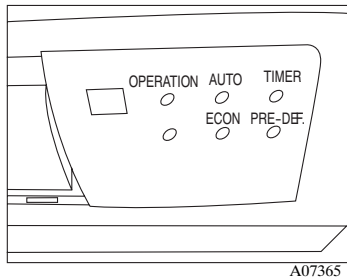

Model size 09

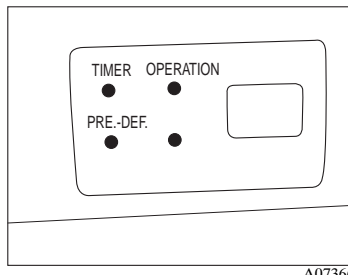

Model size 12

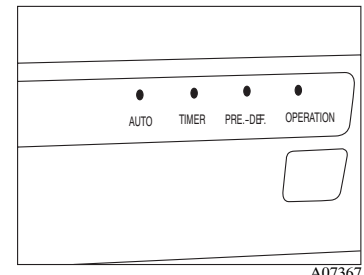

Model size 18-24

Fig. 21 – LED Display Panel